

43

HITACHI Analog-Hybrid Computer

Technical Information Series No.1

**ADDITIONAL ELEMENTS OF HITACHI 505
NECESSARY FOR HYBRID COMPUTING SYSTEM**

(2nd edition)

1 9 6 7

Hitachi, Ltd.

CONTENTS

	Page
1. Introduction	1
2. Configurations and Functions	1
2.1. Functions as the Hybrid Computing System	1
2.2. Voltage Comparator CP-153	5
2.3. Servo-set Potentiometer Panel SP-251	8
2.4. Servo-set Function Generator Panel SFG-251	9
2.5. Selector-Setter Panel and Servo-set Console	9
3. Modification	14

1. Introduction

All the elements necessary for the hybrid computation such as comparators, including electronic switches, servo-set potentiometers, servo-set function generators, etc., have been provided to apply HITACHI 505 Analog Computer to the hybrid computation system. This literature deals only with the functions of HITACHI 505 (hereinafter called 505) in reference to hybrid computation capabilities. For detailed descriptions of the hybrid linkage, a separate literature is provided.

Some of the electronic specifications and/or physical structures described in this literature may be subject to preliminary change without notification at the convenience of manufacturing.

2. Configurations and Functions

2.1. Functions as the hybrid computing system

- (1) Capability of being connected with A-D converter and D-A converter. 505 is designed to be able to accept maximum eight (8) channels of inputs and outputs of A-D converter and D-A converter respectively through Trunk Line Panel TR-151. Analog output signal voltage to be transferred to A-D converter from 505 is limited within $\pm 100V$, while analog input signal voltage to be received from D-A converter is within either $\pm 100V$ or $\pm 10V$.

A-D CONVERTER INPUT

TR-151	A-D
00	0 CH
01	1 CH
02	2 CH
03	3 CH
04	4 CH
05	5 CH
06	6 CH
07	7 CH

D-A CONVERTER OUTPUT

TR-151	A-D
00	0 CH
01	1 CH
02	2 CH
03	3 CH
04	4 CH
05	5 CH
06	6 CH
07	7 CH

- (2) Capability of being connected with servo-set potentiometers. (See 2-3)
- (3) Capability of being connected with servo-set function generators. (See 2-4)

SFG SIGNAL.

TR-151	SFG
32	0 INPUT
33	0 OUTPUT
34	1 INPUT
35	1 OUTPUT
36	2 INPUT
37	2 OUTPUT
38	3 INPUT
39	3 OUTPUT

- (4) Capability of reading out D-C amplifiers and comparators outputs.

Outputs of each D-C amplifier and comparator are capable to be directly read out by the linkage because they, quite individually, have a relay system for their own output selection. Accordingly, the control signal of +24V, 30 mA for each relay must be provided by the linkage for the automatic read out. However, to read out all of the outputs of amplifiers automatically is not supposed to be necessary anyhow, because some of D-C amplifiers combined to non-linear elements of 505 are not necessarily read out. Usually, outputs signals of D-C amplifiers are read out through A-D converter by means of patch connection, if the read-out is required. Automatic output selector is optional and is not described in this literature.

(5) Hybrid linkage controls 505's control mode.

All the control modes of 505 such as RESET, COMPUTE, HOLD, POT-SET, ALL-RESET and REP-OPE can be controlled by an external control signal specified as follows:

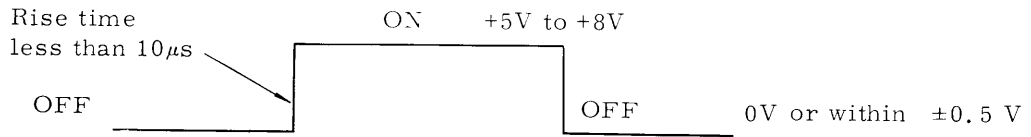

- Impulse period: @ More than 1 ms in case of RESET, COMPUTE and HOLD
 @ More than 10 ms in case of POT-SET and ALL-RESET
 @ To be continued until computation is completed in case of REP-OPE.

EXTERNAL CONTROL
SIGNAL INPUT

J8 CONNECTOR	MODE
A	RESET
B	COMPUTE
C	HOLD
D	POT SET
E	ALL RESET
F	REP OPE

(6) General purpose signal for 505 to control the digital computer (signal Ci) and that for the digital computer to control 505 (signal Co) can be supplied.

Six (6) each channels of signal Ci and signal Co can be connected between 505 and the linkage through TRANK LINE PANEL TR-151. The specifications of signal Ci and signal Co are as follows.

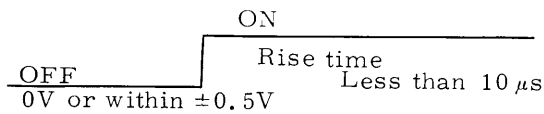

Ci, Co SIGNAL

TR-151	Ci, Co
16	Ci 0
17	Ci 1
18	Ci 2
19	Ci 3
20	Ci 4
21	Ci 5
22	Co 0
23	Co 1
24	Co 2
25	Co 3
26	Co 4
27	Co 5

(7) Output voltage of a digital voltmeter can be read out.
(See the instruction manual for the digital voltmeter)

(8) Interrupt Control

The digital computer which is in the computing state shall have capability to accept an interrupt control signal from 505 so that the digital computer program procedure will be interrupted. Therefore, two (2) channels of input terminals for such purpose shall be provided on the digital computer. These signals are called the "specific signal Ci".

SIGNAL

TR-151	INTERRUPT
28	No 0
29	No 1

(9) Mutual control of clock

- (a) The linkage shall have capability to accept a clock signal from 505 to control a scanning period of an A-D converter and a reading period of a D-A converter.
- (b) Two (2) channels are available for terminals to transmit such clock signals.

TR-151	CLOCK
30	No 0
31	No 1

- (c) Two (2) kinds of specifications are available in 505 as follows.

@ Clock provided by TRUNK LINE PANEL TR-153

Period: 0.1 ms, 1ms, 10 ms, 100 ms

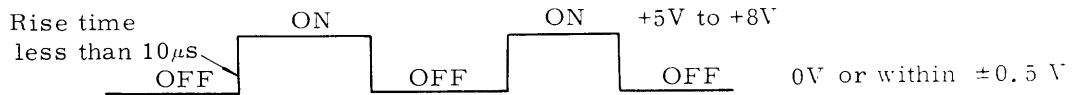

@ Clock provided by TIMER TM-251

Period: 1 ms to 10 s

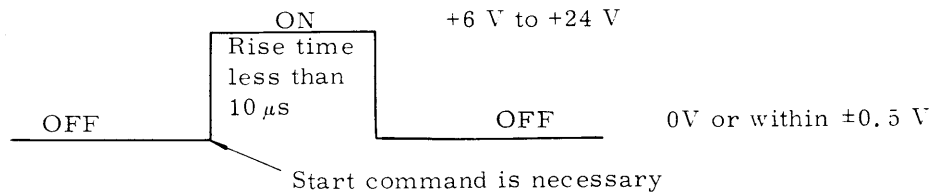

(supplied in the form of nono-stable multi-vibrator)

- (10) Electronic switches which can be controlled by the digital computer are provided in 505.

COMPARATOR CP-153 has 4 each of electronic switches and high speed comparators in its circuit, and can be used for such purposes as scanner of A-D converter, high-speed track-hold, and sample hold by the control from the digital computer.

(See 2.2 for details)

- (11) Capability of control for strip-chart recorder and X-Y recorder.

Paper-driving of a strip-chart recorder and up and down movement of a writing pen of a X-Y recorder shall be controlled by the linkage, and the control lines of those

shall be directly connected from the linkage to each recorder without being passed through 505.

(12) Interlock control

While the patch board of 505 is in "DISENGAGE" condition, the INTERLOCK signal is being sent out. During this period, it is necessary that the interface section keeps sending the "BUSY" signal to digital computer and that the data transfer is halted.

Specifications of the Interlock signal"

+24V in the condition of "DISENGAGED"
open in the condition of "ENGAGED"
(floating)

2.2. Voltage Comparator CP-153

Comparator CP-153 consists of 4 each of high speed comparators and electronic switches, and can be installed in the non linear section of the analog console. This electronic switch can be used not only as a high speed analog switch by being combined with a D-C amplifier, but also as a track-hold circuit and/or a sample hold circuit by being combined with an integrator. In order to apply it to a scanner of A-D converter, connections illustrated on the following picture must be made for each channel of input of A-D converter.

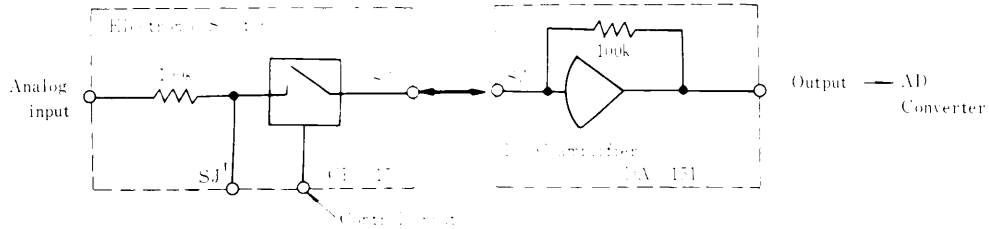

The synchronized clock or general purpose signal C from the linkage must be adapted to the Control Inputs of electronic switches for synchronizing scanning.

The logic output signal of Comparator CP-153 can be that of Logic Element Board CL-252 can be applied for the same purpose for time-synchronized scanning.

Detailed specifications of CP-153 are as follows:

Specifications of Voltage Comparator CP-153

1. Construction	Voltage Comparator CP-153	1
2. Circuits	Comparison circuits	4
	Electronic switches	4
3. Functions		

3.1 Comparison circuits

Generating a logic signal depends on whether the amount of two input voltages is plus or minus.

3.2 Electronic switch

Signal "ON" or "OFF" (Make or break) of an analog input depends on a logic signal applied to its Control Input.

3.3 Track-hold operations

A track-hold operation circuit is obtained by combining the electronic switch with an integrator.

4. Performance

4.1 Performance of the comparator circuits.

(1) Input voltage	-100V ~ +100V
(2) Sensitivity	+50mV or less
(3) Propagation speed	5 μ s or less
(4) Input Impedance	100 K Ω 0.01%/2ea.
(5) Logic output (nominal)	
"1" output	+6V (sum of 2 inputs 0) 5mA
"0" output	0V (sum of 2 inputs 0)
	0V (sum of 2 inputs 0)
	-6V (sum of 2 inputs 0) 5mA

4.2 Performance of the electronic switches

(1) Analog input impedance:	100 K Ω \pm 0.02%
	(including impedance of the electronic switch)
(2) Equivalent OFF impedance:	Approx. 10 ⁸ M Ω
	(when 100V is applied)
(3) Propagation speed:	1 μ s or less
(4) Offset current:	10 ⁻⁹ A or less
(5) Control input impedance:	Approx. 100 K Ω
(6) Input voltage of an analog input:	-100V ~ +100V
That of a control input:	ON: +5V to 8V
	OFF: 0V or within \pm 0.5V
Threshold level:	Approx. +3V

4.3 Performance of the Track-hold (in combination with Integrator IN-151)

(1) Control signal:	Track: +5V to +8V
	Hold: 0V or within \pm 0.5V
(2) Control input impedance:	100 K Ω
(3) Signal input impedance:	100 K Ω
(4) Hold drift:	10mV/sec or less
	(at 0.01 μ F)
(5) Gain error:	\pm 0.02% typical
(6) Phase error:	\pm 0.5° typical
	(at 10 cps, 200V p-p, 0.001 μ F)

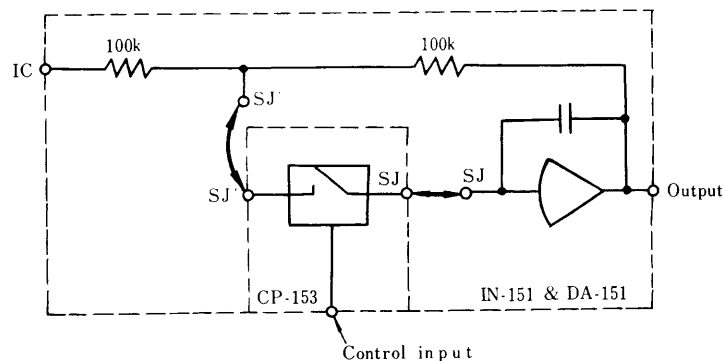

Schematic diagram of CP-153

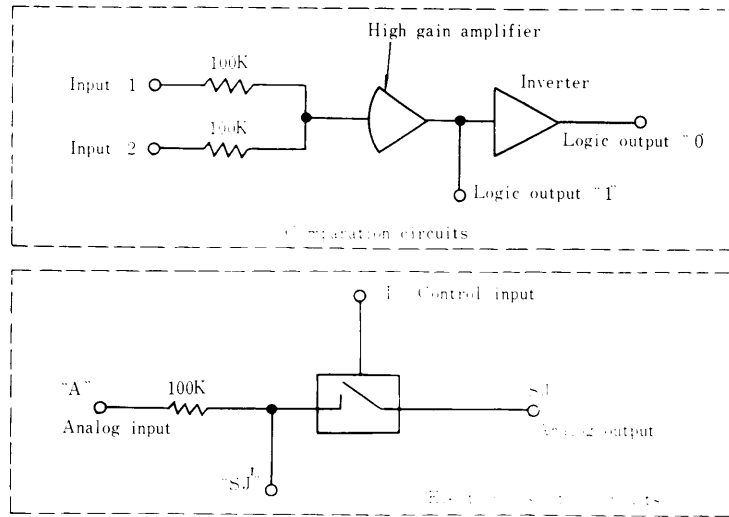

Analog output "SJ" : CP-153 should be mostly connected to the "SJ" terminal of a D-C amplifier.

*Equivalent OFF Impedance means OFF impedance seen from the SJ terminal, and varies with an input voltage applied to "A" point.

OFF impedance of FET: Approx. 100MΩ minimum

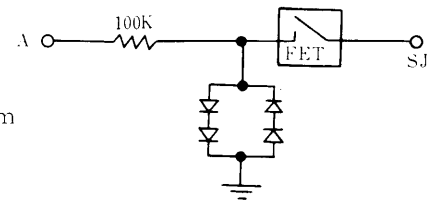

2.3. Servo-set Potentiometer Panel SP-251

Servo-set Potentiometers can be automatically set by the control of the digital computer to change a time constants and/or an initial condition of an integrator on procedure of a program. 18 potentiometers are included in one each SP-251, and this panel is not replaceable in place of Manual-set Potentiometer Panel PT-251, but normally one computing console CS-505C can be constitution max. 3 panels of PT-251 or SP-251 of mixed total 3 panels of PT-251 and SP-251 and requires 3 each of Potentiometer Patch Panel PT-151.

Specifications of these servo-set potentiometers are as follows:

Potentiometer:	10-turn wire-wound type with a driving motor.
Resistance:	30 K Ω
Setting accuracy:	$\pm 0.01\%$ typical $\pm 0.02\%$ max.
Setting time:	1 sec or less typical
Setting method:	<ol style="list-style-type: none">1. Manual TEN-KEYs pushbutton2. Key punched tape (necessary Translator and Key board puncher)3. Setting by the digital computer as the hybrid system.

See 2.5 and 3 for details of the setting and installation methods.

2.4. Servo-set Function Generator Panel SFG-251

SFG-251 can be automatically set by the digital computer and/or a key punched tape as well as can be set by a manual method, and it represents various arbitrary functions.

Specifications of SFG-251 are as follows:

System: Simple addition of segments applied by diodes and transistors.
Segments: 10 each
Length of segments project to X-axis: Arbitrary (-100V to +100V)
Maximum slope: $\pm 5V/V$
Frequency response: 50 kc/s typical -3 dB
20 kc/s minimum
Output capacity: 20mA at $\pm 100V$
Setting methods: 1. Manual TEN-KEY's pushbutton
2. Key punched tape
3. by the digital computer as the hybrid system

See 2.5 and 3 for details of the setting and installation methods.

2.5. Selector Setter Panel and Servo-set Panels

2.5.1 Selector-Setter Panel

This panel controls the address selections and setting values for servo-set potentiometers and servo-set functions generators. This panel consists of three panels of "A", "B" and "C". Panel A and B control only servo-set potentiometers, and all of the panels A, B and C are necessary to control SFG-251, while these three panels operate as translation machines when a setting motion by the digital computer or a key punched tape being applied AO, AI, A2, EX, POT and SP1. of "ADDRESS" part as indicated on the picture of Setter Panel are made up of only pushbuttons and do not have internal mechanical or electronic systems. "SCAN" and "PRINT" are also made up of a pushbutton only and does not have said systems either, since the scanning equipment and printing equipment are optional.

- (1) Setting procedure of servo-set potentiometers.
- (2) Setting by TEN-KEY's type pushbutton
 - i) Depress "SP0" at "SETTER" part.
(Code of servo-set potentiometers selected)
 - ii) Depress TEN-KEY's pushbutton at "SETTER" for the selection of an address, a digit on the first figure next.

For instance, by proceeding above manner, the display lamp at "ADDRESS" will indicate as follows.

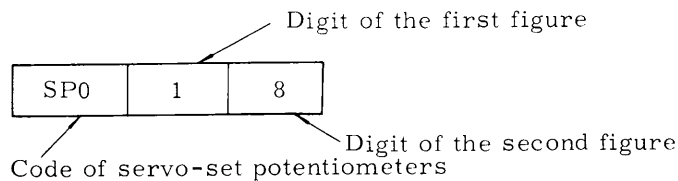

- iii) Depress "SP" in row on right-hand at "SETTER" then, depress TEN-KEY's pushbutton at NUMBER 4 times in turn to set number of 4 figures as a setting value of the selected potentiometer.

iv) Depress "STR" (START) and START lamp at "INDICATOR" light on and again light off after the setting is completed.

(b) Setting procedure by the digital computer in a hybrid operation

- i) Specific Control signal "Co" which means that the setting motion of servo-set potentiometers is going to be on procedure shall be sent from the linkage to 505.
- ii) The signals which represent a potentiometer number and a setting value in the form of "binary coded decimal" (4 bits) shall be sent from a linkage to 505, one after another in the following sequence. This sequence shall be controlled by instructions of the digital computer.

Sequence:

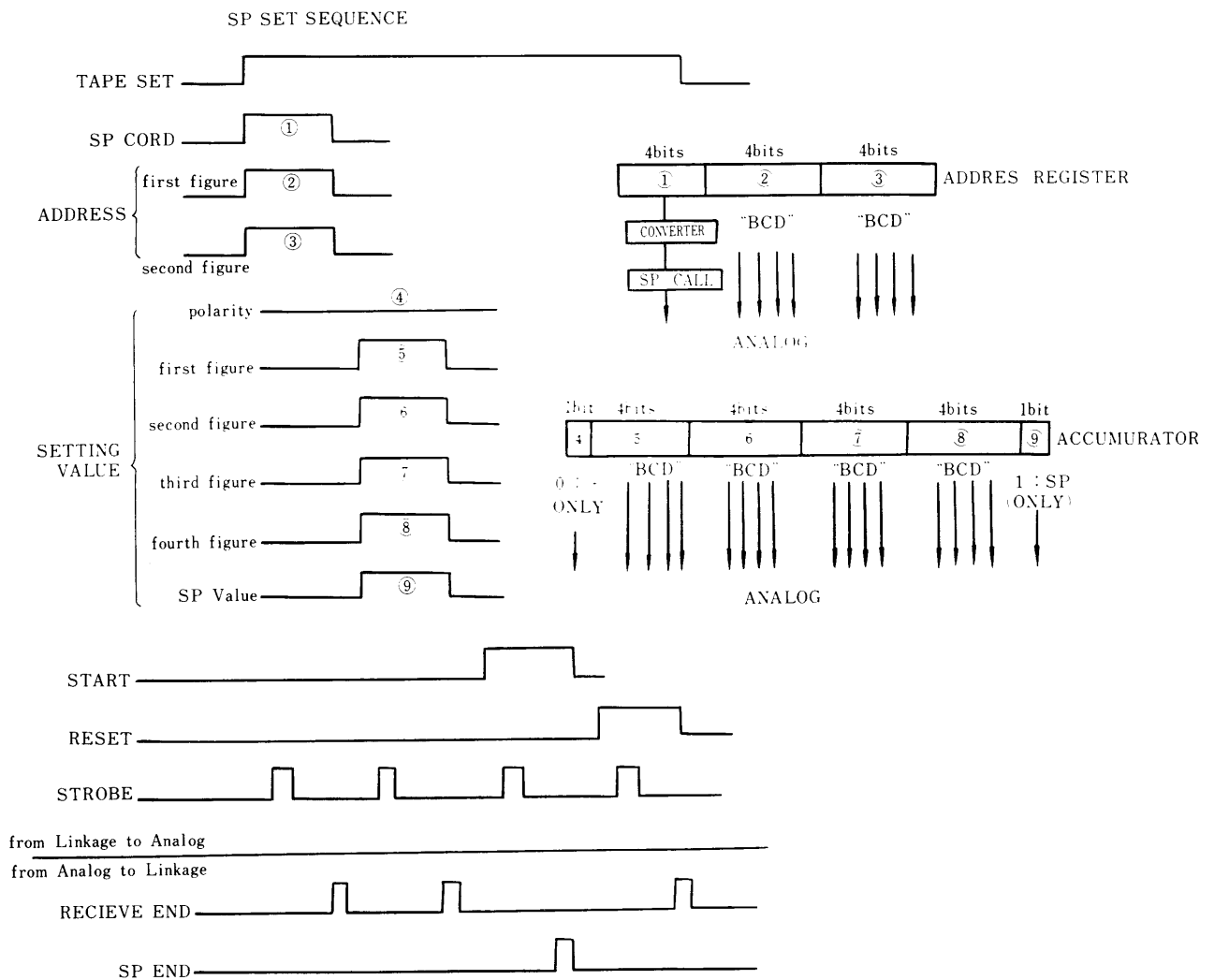

The specifications of these signals including the signal "END" are as follows:

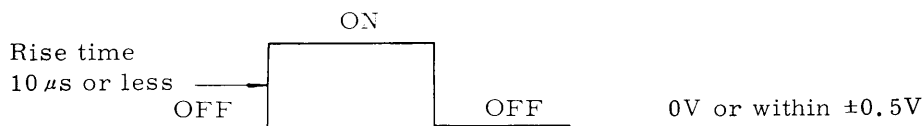

Hold time shall be more than 1 ms.

Note: On procedure of the pot-setting, polarity of a value in a digital computer program must be always set to positive in advance.

That can be selected to either side by programming in computing state.

(2) Setting procedure of servo-set function generators
(see the figure of the panel layout)

(a) Setting by TEN-KEYS pushbutton

- i) Depress "SEG" at SETTER
(a code of servo-set function generators selected)
- ii) Depress TEN-KEYS pushbutton at SETTER for the selection of the address, a digit on the first figure at first and a digit on the second figure next.

For instance, by proceeding above manner, the display lamps at ADDRESS and INDICATOR will indicate as follows:

Code of function generators

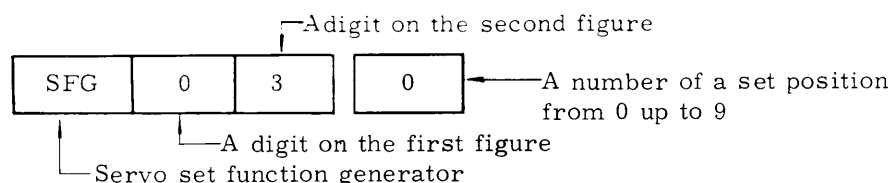

- iii) Depress "CLR" (CLEAR) to reset all the previous setting value.
- iv) Depress "SP" and then "+" or "-" to select X axis setting and polarity of the first breakpoint. Then, depress TEN-KEYS pushbutton at NUMBER 4 times in turn to set a number of 4 figures as a setting value of the selected breakpoint.

When the breakpoint number lamp in indicating "0", a value of the first breakpoint is going to be set and when indicating "1" the second one is going to be set, and so on.

- v) Depress "Y" and then "+" or "-" to select Y axis setting and polarity of the first breakpoint. Then depress TEN-KEYS pushbutton at NUMBER 4 times in turn to set a number of 4 figures as a setting value of the selected breakpoint.
- vi) Depress "STR" (START), and when START lamp at "INDICATOR" light on and again light off it means that the first setting motion for the function generator has been completed.
- vii) Repeat the same motion described above from (iv) thru (vi) for each setting of each remaining breakpoint.

Note: The setting of a function generator must be proceeded from the maximum negative value toward the maximum positive value of X axis.

(b) Setting procedure by a digital computer.

The operating program of the digital computer shall perform the settings of servo-set function generators in the following sequence. The specifications of the control signal to drive a SFG shall be quite the same as those for a SP.

- i) "Specific control signal Co" which means that the setting of a function generator is going to be on procedure shall be sent from the linkage to 505 by an instruction of a digital computer program.
- ii) The signals which represent an address of a function generator and setting values of X and Y axis shall be sent from the linkage to 505, one after another, in the BCD code (4 bits) in the following sequence.

This sequence shall be controlled by instructions of the digital computer.

Sequence:

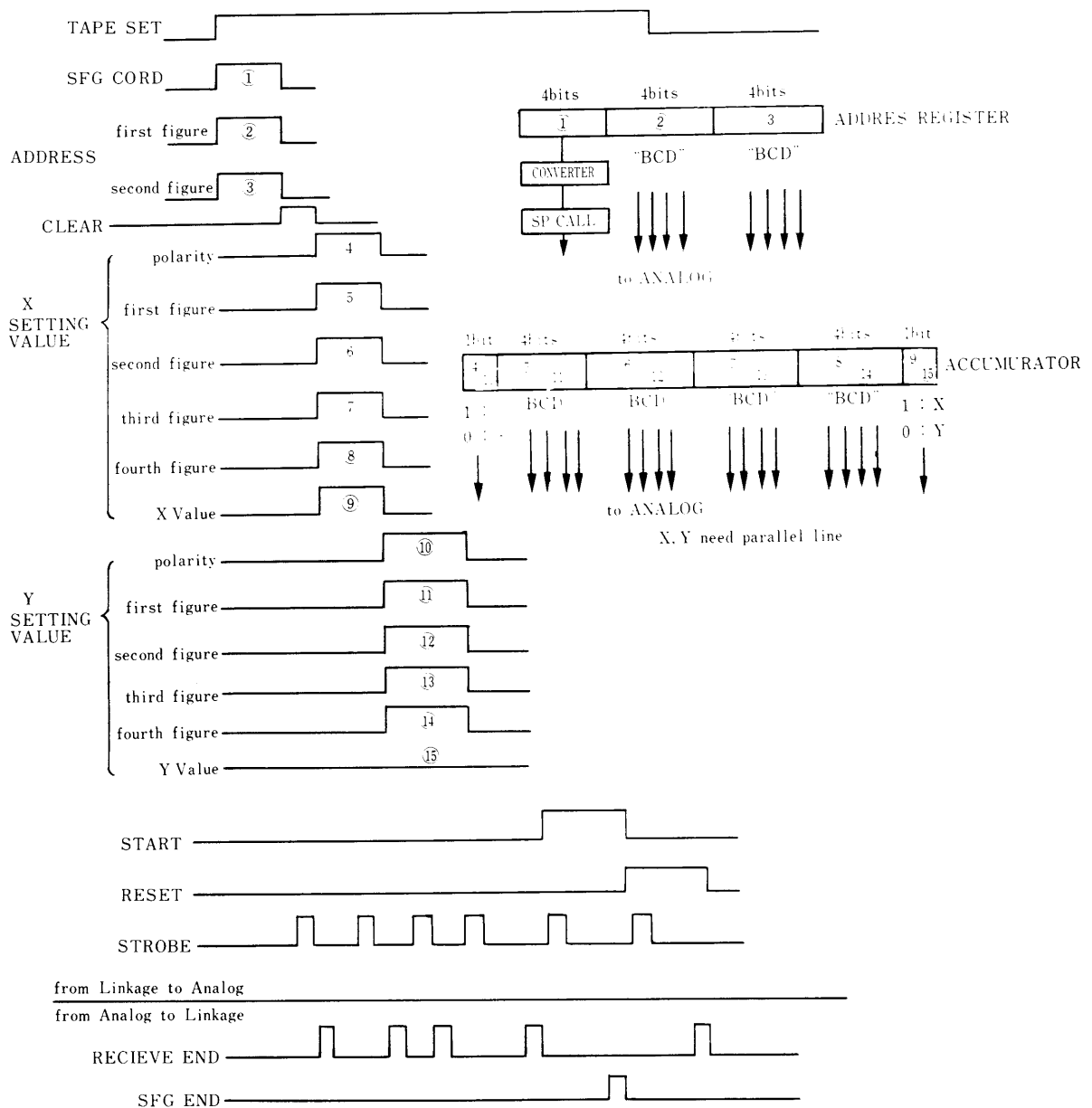

Note: On the setting procedure for a function generator a program of the digital computer must be prepared in order that the setting is proceeded from the maximum negative value toward the maximum positive value of X axis.

2.5.2. Servo set console

The structure of Servo-set console which contains SP-251, SFG-251 Selector-Setter Panel and Power Supply is designed to be floor type Console and its appearance is almost as follows.

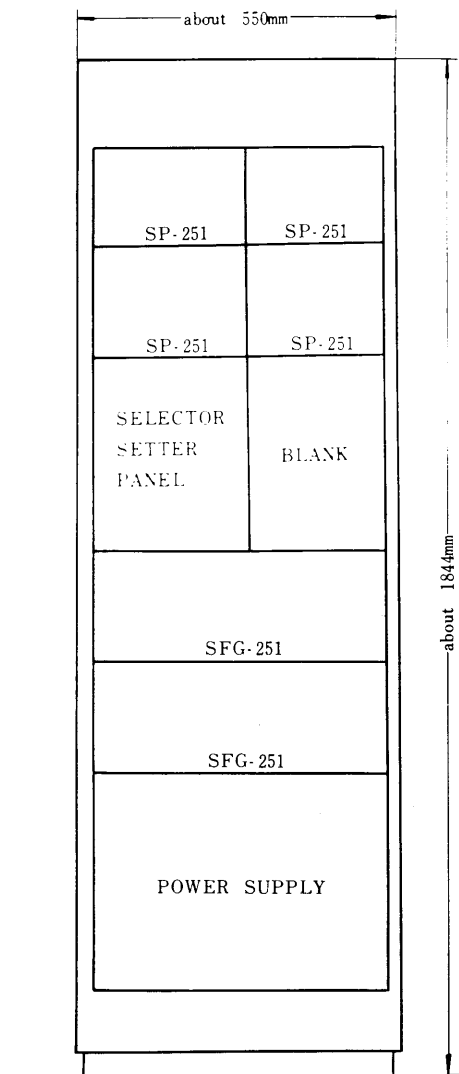

D : about 660mm

Maximum accomodation

Selector Setter Panel A, B and C	1 ea.
SP-251	4 ea. (3 ea max/1 computing console)
SFG-251	2 ea.
Power Supply	1 ea.

2.5.3. Power Supply for Servo-set System

This unit supplies power to each servo-set panel and setter panel. Reference voltage 100V are supplied from Computing Console CS-505A.

3. Modification

3.1. Related to SP-251

SP-251 is connected to the connector designed for Manual Potentiometer Panel PT-251, since SP-251 is replaced for PT-251. Therefore, the modification of the right side board of CS-505C is necessary at customer's expense.

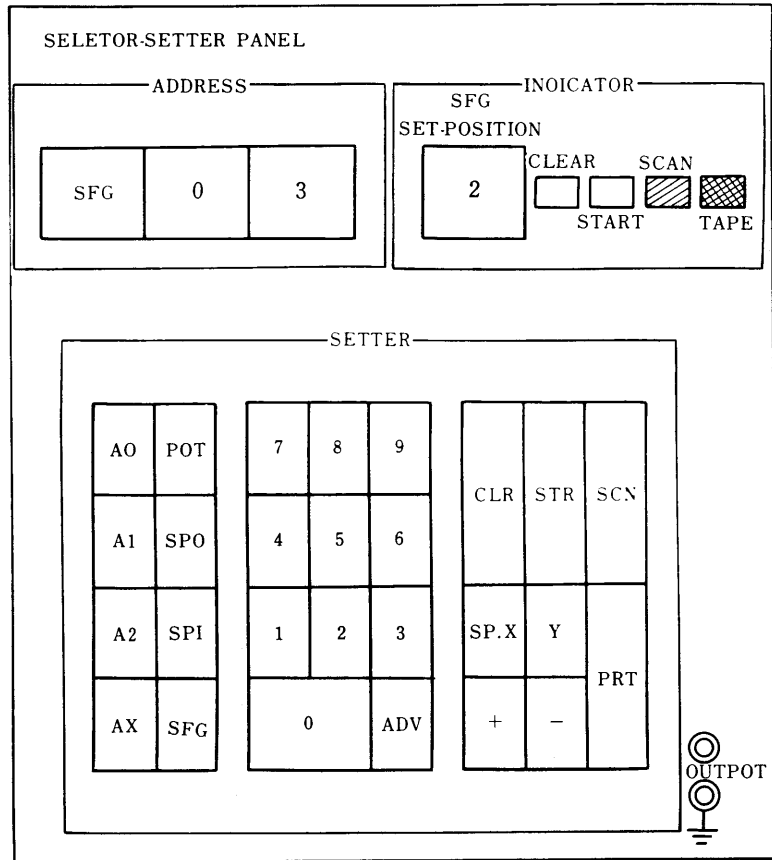

SELECTOR-SETTER PANEL LAYOUT

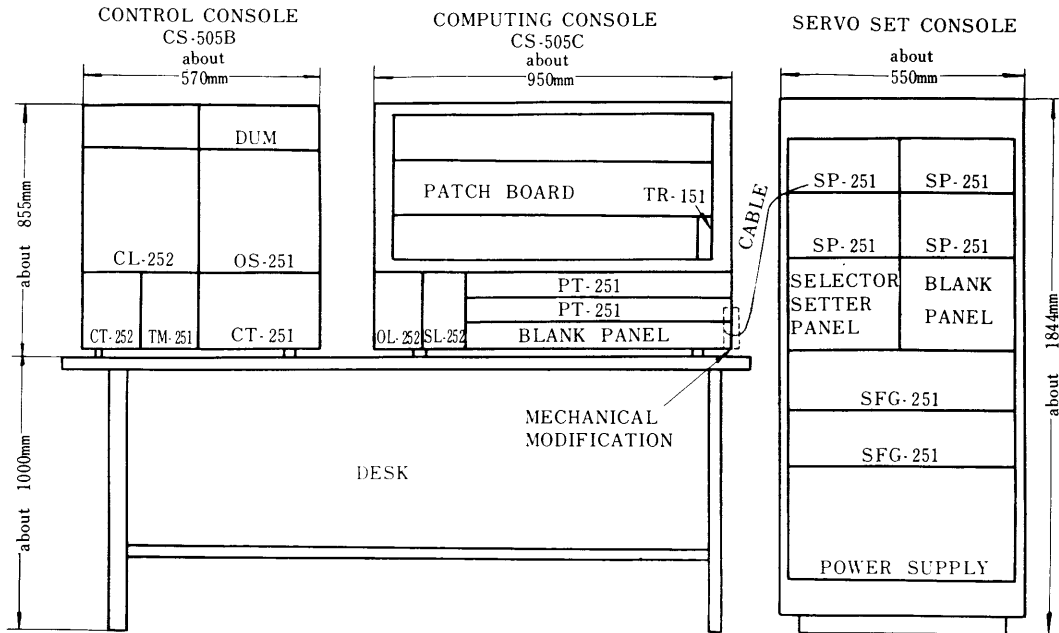

3.2. Related to SFG-251

One each input line and one each output line for each SFG-251 are connected to the patch board through TR-151. Therefore, 1 ea connection cable between CS-505C and Servo-set Console is necessary at customer's expense.

3.3. Modification on 2nd Computing Console

In case that 505 has two each of CS-505C, two each of TR-151 which is provided to each CS-505C are occupied for the signal between one CS-505C and the other CS-505C. Accordingly, transmission in such case, additional TR-151 (3 each altogether) must be mounted into the section to which normally MC-151 is mounted. Additional external connector of 50 pins for additional TR-151 is provided at customer's expense.

3.4. Examples of constitution

The following table describes what kind of units and how many units will be necessary for each following examples from A-J.

- A. 1 each of SP-251 is provided in 505-20
- B. 1 each of SFG-261 is provided in 505-20
- C. 1 each of SP-251 and SFG-251 are provided in 505-20
- D. 1 each of SP-251 is provided in 505-40
- E. 1 each of SFG-251 is provided in 505-40
- F. 1 each of SP-251 and SFG-251 are provided in 505-40
- G. 1 each of SP-251 is provided in 505-80
- H. 1 each of SFG-251 is provided in 505-80
- I. 1 each of SP-251 and SFG-251 are provided in 505-80
- J. 2 each of SP-251 and 1 each of SFG-251 provided in 505-80

Units/Examples	A	B	C	D	E	F	G	H	I	J
SP-251	1		1	1		1	1		1	2
PT-151	3		3	3		3	3		3	6
SFG-251		1	1		1	1		1	1	1
Setter Panel A & B	1	1	1	1	1	1	1	1	1	1
" " C		1	1		1	1		1	1	1
Servo-set console	1	1	1	1	1	1	1	1	1	1
Power Supply	1	1	1	1	1	1	1	1	1	1
External Cable		1	1		1	1		1	1	1
Modification for SP-251	1		1	1		1	1		1	2
Modification for 2nd CS-505C							1	1	1	1
TR-151	1	1	1	1	1	1	3	3	3	3