

Dual Operational Amplifier Type AA1054.2

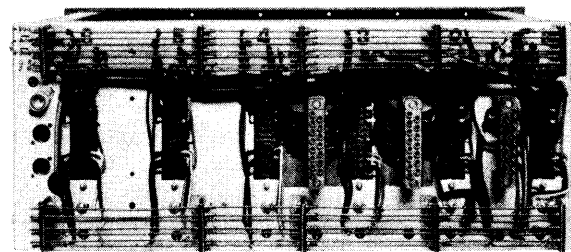
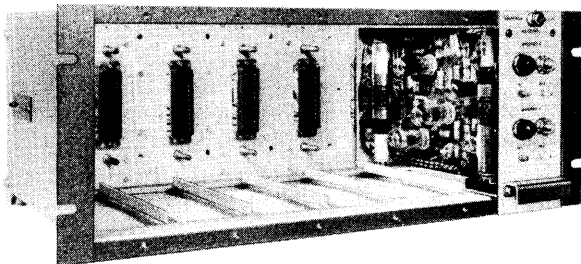

Amplifier Mounting Unit Type TX1055.2

Issue : One
 Date : May 1964
 Mod. Ref. : 1054.2/15
 1055.2/15

SOLARTRON Instruction Manual

DUAL OPERATIONAL AMPLIFIER AA1054.2



The Solartron Electronic Group Ltd.
 Victoria Road, Farnborough, Hants.

Telephone: Farnborough 3000. Telex: 8545 Solartron Fnbro. Cables: Solartron Farnborough.
 A Member of the Schlumberger Group.

CONTENTS

Section		Page
1	Introduction and Data Summary	1
2	Principles of Operation and Brief Description	2
3	Installation and Operation	2
4	Circuit Description	4
5	Test Procedures	4
	List of Components	8

ILLUSTRATIONS

Figure		
1	PL1 Connections	3
2	Typical Chopper Waveform	5
3	DC Slope Measurement	7

APPENDICES

Appendix		
A	DC Amplifier	9

Section 1

INTRODUCTION AND DATA SUMMARY

1.1 Introduction

The Dual Operational Amplifier Type AA 1054.2 is a 'plug-in' unit comprising two independent but identical general purpose d.c. amplifiers. Each amplifier may be used separately for summing, integrating or inverting operations.

Overload indicators, 'set zero' controls and test point facilities for both amplifiers are available on the unit front panel. The inputs, outputs and all power supply connections are made on a 24-way plug at the rear of the unit.

The Solartron Amplifier Mounting Unit Type TX 1055.2 has been designed to house up to six Type AA 1054.2 units. Mating sockets for the amplifier plugs carry the power requirements and allow input and output terminations.

1.2 Data Summary

Each amplifier has the following electrical characteristics:

Output Range	-	±100 volts
Output Current (max.)	-	5mA or 10mA into 10kΩ load
d.c. gain	-	>1 x 10 ⁷ without load
a.c. gain (100c/s)	-	>1 x 10 ⁴
a.c. gain (10c/s)	-	>4 x 10 ⁴
Input Current	-	<10 ⁻¹⁰ amps.
Bandwidth (gain of 10)	-	45kc/s
Stability	-	The amplifier will remain stable with an output load of 10kΩ and 10,000pF, and an input load of 270pF on the summing junction with 1MΩ or capacitive feedback.
Power Requirements	-	+300 volts d.c.)) -300 volts d.c.)) Stabilised -200 volts d.c.)) 6.3 volts a.c. at approximate d.c. bias of +25 volt, with respect to common rail. 9.5 volts a.c. at approximate d.c. bias of -100 volt, with respect to common rail.

Note: Solartron Power Supply Type AS 1104.2 has been designed to supply twelve Type AA 1054.2 units - i.e., twenty-four amplifiers.

Mechanical Details	-	Type AA 1054.2
Dimensions	-	Height: 7 in. 17.78 cm
		Width: 2.8 in. 7.1 cm
		Depth: 11.5 in. 29.2 cm (overall)
		Weight: 3 lbs. 1.36 Kg.

All units, sub-assemblies and parts are interchangeable.

Mechanical Details	-	Type TX 1055.2
Dimensions	-	Height: 7 in. 17.78 cm
		Width: 19 in 48.26 cm
		Depth: 12.25 in 31 cm
		Weight: 7 lbs. 3.18 Kg

Section 2

PRINCIPLES OF OPERATION AND BRIEF DESCRIPTION

2.1 Principles of Operation

See Section 2.1 of Appendix 'A'.

2.2 Brief Description

The Dual Operational Amplifier Type AA 1054.2 is designed for rack mounting in conjunction with Amplifier Mounting Unit Type TX 1055.2.

Valves are located on the main printed circuit boards, and the chopper relays plug into separate sub-assemblies sitting in light traps to shield the input diode limiters.

The printed circuit boards are in turn fixed to the amplifier chassis, the whole forming a unit of open construction. (See Frontispiece)

Note: Printed circuit boards 00P501/503 comprising amplifier 'A' are the rearmost pair.

Section 3

INSTALLATION AND OPERATION

3.1 Unit Connections

Plug 1 pin assignments for the Type AA 1054.2 Dual Operational Amplifier are shown in Fig. 1. The heater supply connected between pins 9 and 21 feeds four valves and must be connected on one side to a d. c. potential of +25 volts, and the heater supply connected between pins 10 and 22, feeding two valves, must be connected on one side to a d. c. potential of -100 volts.

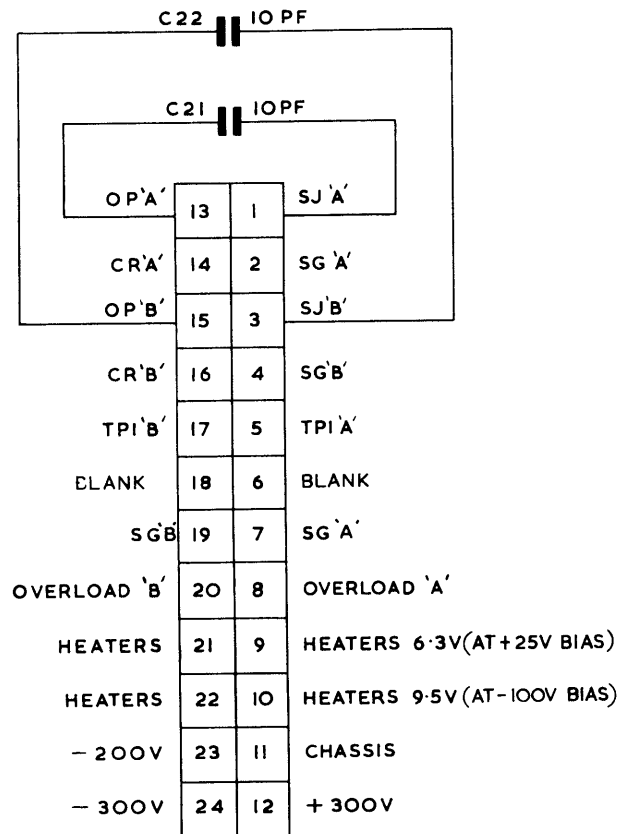

Fig. 1 - PL1 Connections

The above requirements are met by the Solartron Type AS1104.2 Power Supply Unit mentioned in Section 1.2.

Plug and socket assignments for the Type TX1055.2 Amplifier Mounting Unit are shown in the circuit diagram at the end of the Manual - sockets SK1 to SK6 providing connectors for six Type AA1054.2 units, sockets SK7 and SK8 being used for patching and plug PL1 for the power supply connections.

3.2 Operation

If not used in conjunction with the Type TX1055.2 Amplifier Mounting Unit, make suitable connections to the plug at the rear of the Type AA1054.2 amplifier.

In either case patch as required and allow several minutes for the equipment to warm up. Connect an oscilloscope at a sensitivity of about 100 mV/cm to the amplifier test points marked T.P.1. on the front panel in turn for amplifiers 'A' and 'B' and adjust the associated 'set zero' potentiometers to give zero mean d. c. component in the observed waveform.

The provision of input and feedback components must be determined by the parameters of the application in which the amplifiers are to be used. It is not advisable to operate the amplifiers unless some feedback component is incorporated.

C21 and C22 (see Fig. 1) ensure high frequency stability under all conditions of operation within the specification (see Section 1.2 - Stability).

Section 4

CIRCUIT DESCRIPTIONS

4.1 Dual Operational Amplifier Type AA1054.2

See Section 3 of Appendix 'A'.

4.2 Amplifier Mounting Unit Type TX1055.2

The Amplifier Mounting Unit Type TX 1055.2 accommodates six Dual Operational Amplifiers Type AA1054.2 and can be mounted in a standard 19-inch rack.

Each amplifier plug has a corresponding socket on the mounting unit - sockets SK1 to SK6. The h.t., heater, common rail, signal ground and chassis outlets from the sockets are commoned and brought out to a connector PL1. C1 to C4 serve to decouple the h.t. supplies at PL1.

Output and summing junction outlets from each amplifier socket are taken to sockets SK7 and SK8 respectively and the overload outlets are commoned and brought out to socket SK9.

Section 5

TEST PROCEDURES

5.1 Equipment Required:

The following test equipment is required:

- (a) A signal generator to give 0.1c/s - 10c/s and 100c/s at 10 volts r.m.s. e.g., Solartron CO 546.
- (b) A single beam oscilloscope with facilities for measuring between 1 millivolt and 300 volts on both a.c. and d.c. ranges to an accuracy of 2%, e.g., Solartron CD 513.
- (c) A 20k Ω /volt multi-range meter of accuracy better than 3% full scale deflection e.g., Avometer Model 8.
- (d) Power supplies of +300, -300, -200 volt d.c. at 50 milliamps. 6.3 and 9.5 volt a.c. at d.c. bias potentials of approximately +25 and -100 volt d.c. respectively, e.g., Solartron AS 1104.2.
- (e) Twin amplifier test set as shown in Fig.5.

5.2 Test 1 - Power Supplies

Connect +300 volt d.c., -300 volt d.c., -200 volt d.c. and heater (6.3 volt a.c. and 9.5 volt a.c.) supplies to the terminal block on the amplifier test set and plug the low frequency signal generator into SKD. Set switches SWA to position 1, SWB to position A, SWC to position 2, SWF to position 2 and SWG to 'OFF'. Plug the amplifier into the 24-way socket on the end of the flying lead. Allow time for the unit to warm up and then check the following voltages at the points stipulated within the unit.

- (a) -300 (± 10) volt d.c. between pin 24 of plug 1 and chassis (pin 24 is negative) using the 20k Ω /volt meter on the 500 volt d.c. range.

- (b) +300 (± 10) volt d.c. between pin 12 of plug 1 and chassis using the 20k Ω /volt meter on the 500 volt d.c. range.
- (c) -200 (± 10) volt d.c. between pin 23 of plug 1 and chassis (pin 23 is negative) using the 20k Ω /volt meter on the 250 volt d.c. range.
- (d) 6.3 (± 0.3) volt a.c. between pins 9 and 21 of plug 1 using the 20k Ω /volt meter on the 10 volt a.c. range.
- (e) +25 volt d.c. approximately between pin 9 and chassis using the 20k Ω /volt meter on the 100 volt d.c. range.
- (f) 9.5 (± 0.3) volt a.c. between pins 10 and 22 of plug 1 using the 20k Ω /volt meter on the 10 volt a.c. range.
- (g) -100 volt d.c. approximately between pin 10 and chassis using the 20k Ω /volt meter on the 250 volt d.c. range.

5.3

Test 2 - Chopper Waveform and DC Offset.

- (a) With the test set connected as in 5.2, switch SWF to position 3, monitor the test point, SKE, with the oscilloscope on the 1 volt/cm. a.c. range. Check that the chopper waveform is stable and set the chopper signal for zero d.c. component by adjusting RV1 on the front panel of the amplifier (See Fig. 2).

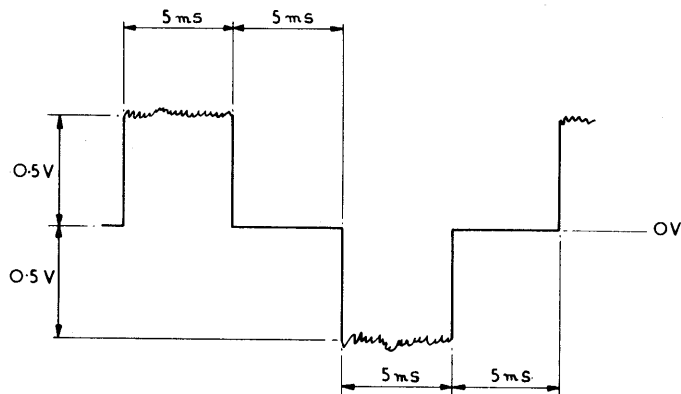

Fig. 2 - Typical Chopper Waveform

- (b) With the test set connected as in 5.3 (a), switch SWF to position 4 and SWB to position B. Repeat the procedure of 5.3 (a), adjusting RV2 on the front panel of the amplifier to balance chopper signal. Amplitude ± 2 volt peak-to-peak.
- (c) With the test set connected as in 5.3 (b) switch SWB to position A, SWC to position 2 and SWF to position 3. Monitor the test point (SKC) with the 20k Ω /volt meter on the 2.5 volt d.c. range and adjust RV1 for zero reading. Switch SWF to position 2 and monitor the d.c. off-set on 50 μ A range.

It should not exceed 100 millivolt. (Note: 50 μ A = 125mV f.s.d. on AVO model 8).

- (d) With the test set connected as in 5.3 (c), switch SWB to position B and SWF to position 4. Adjust RV2 for zero reading. Switch SWF to position 2 and monitor the d.c. off-set on the 50 μ A range. It should not exceed 100 millivolt.
- (e) With conditions as for 5.3 (d) check with the oscilloscope that the chopper waveforms appear on Test Point 1 of amplifier 'A' and Test Point 1 of amplifier 'B'; both points on the front panel of the amplifier. Remove the 20k Ω /volt meter from SKC.

5.4

Test 3 - Noise

- (a) With the test set connected as for 5.3 (e) switch SWB to position A, SWC to position 6 and SWF to position 2. With the oscilloscope on the 100 millivolt a. c. range, check that the output is not oscillating and measure the amplitude of the noise. It should not be greater than 75 millivolt peak-to-peak.
- (b) With the test set connected as in 5.4 (a) switch SWB to position B. Check that the output is not oscillating and measure the amplitude of noise. It should not be greater than 75 millivolt peak-to-peak.

5.5

Test 4 - Leakage

- (a) With the test set connected as for 5.4 (b), switch SWB to position A and SWC to position 7. Press SWE. Connect the 20k Ω /volt meter on the 50 μ A range to test point (SKC). Release SWE. Measure the voltage on the meter 10 seconds after releasing SWE. It should not exceed 100 millivolt.
- (b) With the test set connected as for 5.5 (a) switch SWB to position B and repeat the procedure of 5.5 (a).

5.6

Test 5 - Stability.

- (a) Remove the 20k Ω /volt meter. With the test set connected as for 5.5 (b), switch SWB to position A, SWC to position 8, and SWG to 'ON'. Monitor SKE or SKC with the oscilloscope on the 300 volt a. c. range and adjust the oscillator for 200 volt peak-to-peak, 100 cycles per second at SKE or SKC. Switch SWF to position 1 and adjust the oscilloscope range accordingly. (Range 100mV/cm). Now press and release SWD and check that the amplifier is stable and gives no sign of oscillation. Repeat this procedure for SWA positions 2 to 8 inclusive.
Note that by pressing and releasing SWD, the summing junction of the amplifier under test is temporarily shorted to signal ground: this being a method of starting non-linear oscillation.
- (b) With the test set connected as for 5.6 (a), switch SWB to position B and repeat the procedure outlined in 5.6 (a).
- (c) With the test set connected as for 5.6 (b), switch SWB to position A, SWC to position 9 and SWF to position 2. Set the oscillator to give 200 volt peak-to-peak, 100 cycles per second, at SKE or SKC. Now switch SWF to position 1 and repeat the procedure given in 5.6 (b).
- (d) With the test set connected as for 5.6 (c) switch SWB to position B and repeat the procedure for 5.6 (c).
- (e) With the test set connected as for 5.6 (d) switch SWB to position A. Monitor the voltage on Test Point 2 on the front panel of amplifier 'A' with the oscilloscope on the 300 volt a. c. range. It should be not less than 175 volt peak-to-peak.
- (f) With the test set connected as for 5.6 (e) switch SWB to position B. Monitor the voltage on Test Point 2 of amplifier 'B' with the oscilloscope. It should be not less than 175 volt peak-to-peak.

5.7

Test 6 - Overload.

- (a) With the test set connected as for 5.6 (f) switch SWA to position 3, SWB to position A and SWF to position 5. Increase the drive of the oscillator until lamp LP1, the indicating neon on the front panel of the amplifier lights. Measure the voltage at the test point with the oscilloscope on the 30 volt range. It should indicate not less than 5 volt peak-to-peak.

- (b) With the test set connected as in 5.7 (a), switch SWB to position B and SWF to position 6; and with lamp LP2 lit, measure the test point voltage as in 5.7 (a).

5.8 Test 7 - AC Gain.

- (a) With the test set connected as for 5.7 (b), switch SWA to position 1, SWB to position A, SWC to position 5 and SWF to position 2. Set the oscillator to give 200 volt peak-to-peak, 100 cycles per second at SKE or SKC and measure with the oscilloscope on the 300 volt a.c. range. Now switch SWF to position 1 and measure the test point voltage on the 30 millivolt range of the oscilloscope. It should be not greater than 20 millivolt peak-to-peak.
- (b) With conditions as for 5.8 (a), switch SWB to position B and measure again. The test point voltage should not exceed 20 millivolt peak-to-peak.
- (c) With conditions as for 5.8 (b) switch SWB to position A and SWF to position 2. Decrease the frequency of the oscillator to 10 cycles per second and set it to give 200 volt peak-to-peak at SKE or SKC. Now switch SWF to position 1 and measure the test point voltage on the 30 millivolt range of the oscilloscope. It should be not greater than 5 millivolt peak-to-peak.
- (d) With conditions as for 5.8 (c) switch SWB to position B and re-measure. The test point voltage should not exceed 5 millivolt peak-to-peak.

5.9 Test 8 - DC Gain.

- (a) With the test set connected as for 5.8 (d) switch SWC to position 4 and SWF to position 7. Monitor SKE or SKC with the oscilloscope on the 300 volt d.c. range and drive the time-base of the oscilloscope with the oscillator output. Set the oscillator to give 250 volt peak-to-peak, 0.1 of a cycle per second, at SKE or SKC.
- (b) With the test set connected as for 5.9 (a) switch SWF to position 2 and with the oscilloscope on the 300 millivolt d.c. range, measure the d.c. slope of the line ignoring the super-imposed a.c. noise. It should not exceed 50 millivolt, as indicated in Fig. 3.
Note that although SWB is switched to position B, the gain of amplifier 'A' is being measured.
- (c) With the test set connected as for 5.9 (b) switch SWB to position A and re-measure the d.c. slope. It should not exceed 50 millivolt.

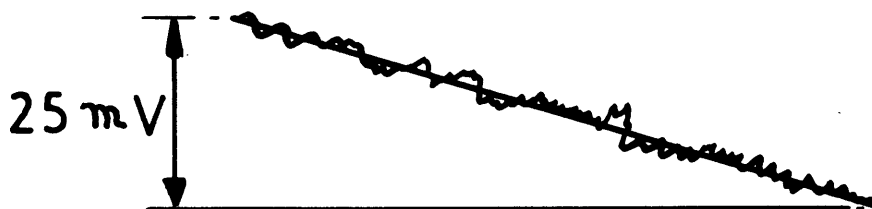

Fig. 3. DC Slope Measurement

LIST OF COMPONENTS

Printed Circuit Board Assembly OOP501)
 Printed Circuit Board Assembly OOP503) See Appendix 'A'

RESISTORS VARIABLE

Circuit Ref.	Description	Value Ohms	Tol %	Rating Watts	Manufacturer and Type
RV1	(Amp 'A') Wire Wound	1K	10	1	Colvern CLR 1206/95/S
RV1	(Amp 'B') Wire Wound	1K	10	1	Colvern CLR 1206/95/S

CAPACITORS

Cct. Ref.	Value μ F	Tol. %	Rating Volts	Manufacturer & Type	
AMP 'A'					
* C6	.047	10	400	Wima Tropyfol	M. MP1
AMP 'B'					
* C6	.047	10	400	Wima Tropyfol	M. MP1
AMP 'A'					
* C7	330pF	2	500	Suflex	H.S. Po.
AMP 'B'					
* C7	330pF	2	500	Suflex	H.S. Po.
AMP 'A'					
* C8	.0033	10	400	Wima Tropyfol	F. MP1
AMP 'B'					
* C8	.0033	10	400	Wima Tropyfol	F. MP1

Circuit Ref.	Description	Value μ F	Tol	Rating Volts	Manufacturer and Type
C21	Polystyrene Tub.Ins.	10pF	\pm 1pF	500	G.E.C.
C22	Polystyrene Tub.Ins.	10pF	\pm 1pF	500	G.E.C.

MISCELLANEOUS

Cct. Ref.	Description	Manufacturer & Type	
ILP1	(Amp 'A') Lamp (without Resistor) Clear	Arcoelectric	SL80
ILP1	(Amp 'B') Lamp (without Resistor) Clear	Arcoelectric	SL80
TP1	(Amp 'A') Socket Pressfit Red	Sealectro	SKT-50
TP1	(Amp 'B') Socket Pressfit Red	Sealectro	SKT-50
TP2	(Amp 'A') Socket Pressfit Yellow	Sealectro	SKT-50
TP2	(Amp 'B') Socket Pressfit Yellow	Sealectro	SKT-50
	Plug Red (2 off)		
	Plug Yellow (2 off)		
PL1	Plug 24-Way	Sealectro	FT-M-7
		McMurdo	XRP24

* On Printed Circuit Board OOP501

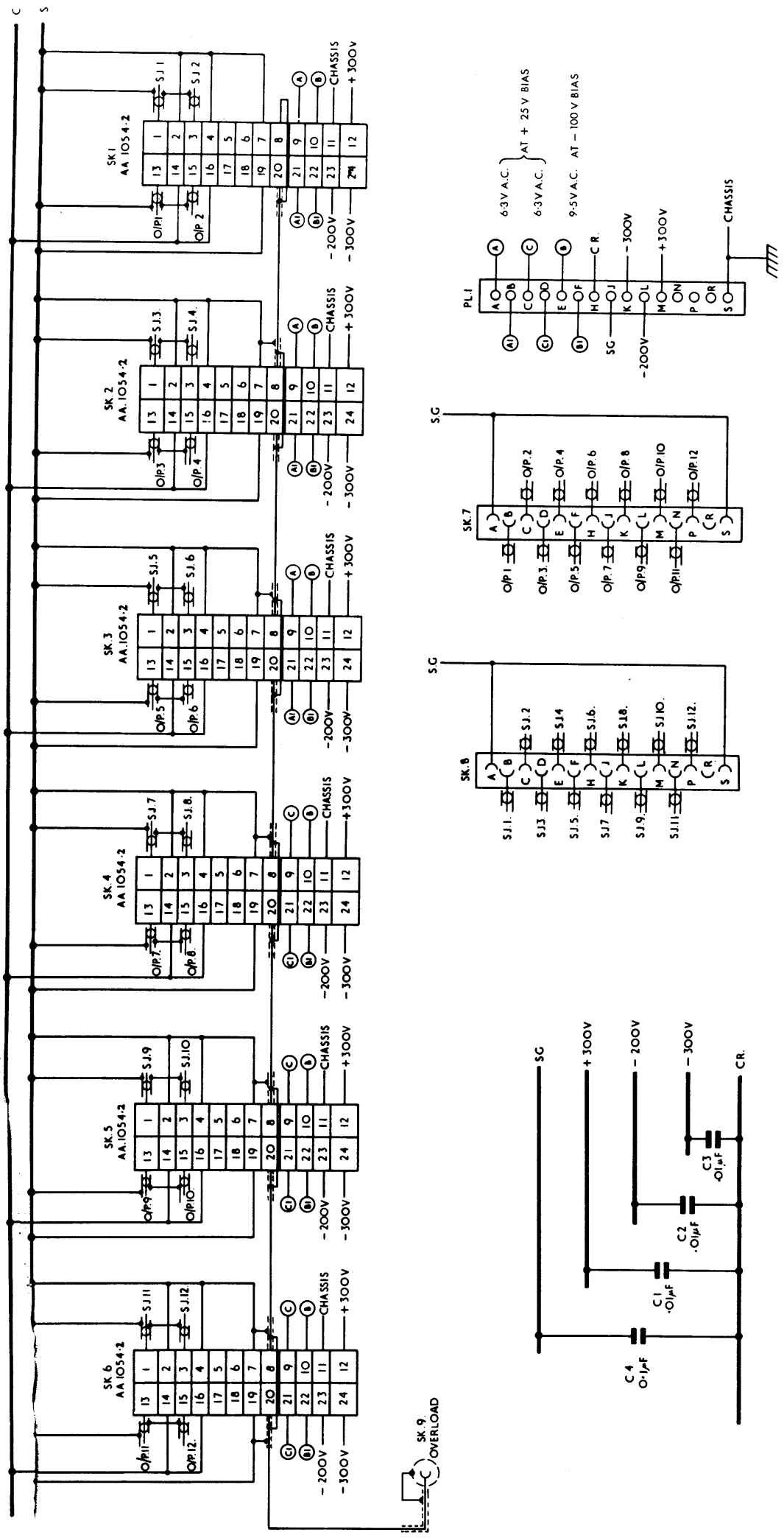

Fig. 5 - TX1055. 2 Circuit Diagram

APPENDIX 'A'

DC AMPLIFIER

used on

AA 1054.2	Dual Operational Amplifier
AS 1102	+100V and -100V Reference Supply
TR 1322	Mark-Space Multiplier
TR 1323	Mark-Space Multiplier

Issue : One

Date : January, 1964.

LIST OF CONTENTS

Section	
1	INTRODUCTION AND DATA SUMMARY
1.1	Introduction
1.2	Data Summary
2	PRINCIPLES OF OPERATION AND BRIEF DESCRIPTION
2.1	Principles of Operation
2.2	Brief Description
3	CIRCUIT DESCRIPTION AND OPERATION
3.1	AC Channel
3.2	DC Channel
3.3	Mixer Stage
3.4	Output Stage
3.5	Operation
3.6	Overload Indication

LIST OF COMPONENTS

DIAGRAMS

Figure	
1	Component Location : Printed Circuit Board OOP501
2	Component Location : Printed Circuit Board OOP503
3	Circuit Diagram : OOP501/503

2.2 Brief Description

The d. c. amplifier comprises two printed circuit boards - OOP501 upon which the valves and associated components are mounted, and OOP503 holding the chopper relay and input resistors.

Harwin pin terminations on the boards provide for connecting power supplies and linking to panel mounted components, - i. e. test points, overload indicator, adjustment potentiometer.

Holes drilled in the boards to accommodate 4BA bolts facilitate mounting in the respective equipments.

Section 3

CIRCUIT DESCRIPTION AND OPERATION

3.1 AC Channel

Signals at the input junction S. J. (pin 5) are a. c. coupled to triode V1A grid via capacitor C1. Diode limiter MR5 and MR6 in parallel with the input clamps the signal at approximately ± 0.6 V to prevent the build-up of nonlinear lockout oscillations.

The amplified output from V1A anode is coupled to the control grid of pentode V1B by C5. R8 with C6 and R13 with C7 are phase correction components.

3.2 DC Channel

Signals from the input junction SJ (pin 5) are taken via R4, R5 to one contact of chopper relay RL1, the purpose of which is to alternately connect R4 to ground and leave it free at a frequency of 100 c/s. Thus a pulsed signal at triode V2A grid is produced, the amplitude of which is proportional to that at the input.

The amplified signal at V2A anode is a. c. coupled by C13 to pentode V2B grid for further amplification. A second contact on RL1, coupled to V2B anode by R28-C16, synchronously rectifies the pulsed signal to provide d. c. restoration.

MR3 in series with R42 energises RL1 coil from the 6.3 V heater 'A' supply.

3.3 Mixer Stage

The d. c. signal at C16-RL1 junction is applied to mixer pentode V1B grid via R11 and controls the operational d. c. conditions at the anode.

V1B cathode potential is determined by the setting of potentiometer RV1, and this influences the d. c. levels of the following direct coupled output stage.

3.4 Output Stage

Triode-pentode V3A-V3B in cascode comprises an amplifier enabling considerable gain to be achieved whilst being capable of delivering a reasonable output current.

R40, R41 and VT1 form a potential divider across the mixer output. VT1, in the lower limb, has a high dynamic impedance but a low d. c. volt drop. Thus a large d. c. volt drop

across R40-R41 can be achieved without serious signal loss, the signal at R41-VT1 junction going to V3B grid.

Zener diode MR4 is a 22 volt base clamp for VT1, while MR2 prevents VT1 collector potential from exceeding 25 volts under switch-on conditions - i.e., should h.t. be applied before V3B has warmed-up, to enable the cathode-grid diode action to function.

R34 is provided in series with a test point to prevent an accidental short circuit occurring. V3A cathode is prevented from exceeding approximately 150 V with respect to the common rail by voltage dependent resistor R43.

3.5 Operation

On positive going signals current from the amplifier is taken from V3A cathode. On negative going signals V3A virtually cuts off and current is taken from the anode of V3B. When this current is such that the potential across R33 exceeds 18 volts, Zener diode MR1 conducts to allow the extra current to flow through R21.

3.6 Overload Indication

The presence of an overload condition is detected by a neon indicator which strikes when the output from the d.c. channel at the junction of C16 and RL1 reaches approximately 60 volts.

COMPONENTS LISTS

PRINTED CIRCUIT BOARD OOP501

RESISTORS

Cct. Ref.	Description	Value Ohms	Tol. %	Rating Watts	Manufacturer & Type	
R1	Not fitted					
R2	Res. Comp. GR2. Ins.	1M	10	$\frac{1}{4}$	Dubilier	BTT
R3	Res. Comp. GR2. Ins.	100	10	$\frac{1}{4}$	Dubilier	BTT
R7	Res. Comp. GR2. Ins.	100	10	$\frac{1}{4}$	Dubilier	BTT
R8	Res. Comp. GR2. Ins.	200K	10	$\frac{1}{4}$	Dubilier	BTT
R9	Res. Comp. GR2. Ins.	680	10	$\frac{1}{4}$	Dubilier	BTT
R10	Res. Comp. GR2. Ins.	2.7K	10	$\frac{1}{4}$	Dubilier	BTT
R11	Res. Comp. GR2. Ins.	4.7M	10	$\frac{1}{4}$	Dubilier	BTT
R12	Res. Comp. GR2. Ins.	100	10	$\frac{1}{4}$	Dubilier	BTT
R13	Res. Comp. GR2. Ins.	180K	7	1	Welwyn Metox	F22
R14	Res. Comp. GR2. Ins.	1.8K	10	$\frac{1}{4}$	Dubilier	BTT
R15	Res. Comp. GR2. Ins.	110K	7	1	Welwyn Metox	F22
R16	Res. Comp. GR2. Ins.	27K	10	$\frac{1}{4}$	Dubilier	BTT
R17	Res. Comp. GR2. Ins.	1M	10	$\frac{1}{4}$	Dubilier	BTT
R18	Res. Comp. GR2. Ins.	100	10	$\frac{1}{4}$	Dubilier	BTT
R19	Res. Comp. GR2. Ins.	56K	10	$\frac{1}{4}$	Dubilier	BTT
R20	Res. Comp. GR2. Ins.	100	10	$\frac{1}{4}$	Dubilier	BTT
R21	Res. Comp. GR2. Ins.	470	10	$\frac{1}{4}$	Dubilier	BTT
R22	Res. Comp. GR2. Ins.	22K	10	$\frac{1}{4}$	Dubilier	BTT
R23	Res. Comp. GR2. Ins.	220K	10	$\frac{1}{4}$	Dubilier	BTT
R24	Res. Comp. GR2. Ins.	3.9K	10	$\frac{1}{4}$	Dubilier	BTT
R25	Res. Comp. GR2. Ins.	3.3M	10	$\frac{1}{4}$	Dubilier	BTT
R26	Res. Comp. GR2. Ins.	100	10	$\frac{1}{4}$	Dubilier	BTT
R27	Res. Comp. GR2. Ins.	180K	10	$\frac{1}{4}$	Dubilier	BTT
R28	Res. Comp. GR2. Ins.	47K	10	$\frac{1}{4}$	Dubilier	BTT
R29	Res. Comp. GR2. Ins.	2.2K	10	$\frac{1}{4}$	Dubilier	BTT
R30	Res. Comp. GR2. Ins.	820K	10	$\frac{1}{4}$	Dubilier	BTT
R31	Res. Comp. GR2. Ins.	560K	5	$\frac{1}{4}$	Dubilier	BTT
R32	Res. Comp. GR2. Ins.	100	10	$\frac{1}{4}$	Dubilier	BTT
R33	Res. Comp. GR2. Ins.	4.7K	10	$\frac{1}{4}$	Dubilier	BTT
R34	Res. Comp. GR2. Ins.	47K	10	$\frac{1}{4}$	Dubilier	BTT
R35	Res. Comp. GR2. Ins.	6.8K	10	$\frac{1}{4}$	Dubilier	BTT
R36	Res. W. W. Vit.	4.7K	10	3	Painton	P306A
R37	Res. Comp. GR2. Ins.	22K	10	$\frac{1}{4}$	Dubilier	BTT
R38	Res. Comp. GR2. Ins.	330K	10	$\frac{1}{4}$	Dubilier	BTT
R39	Res. Comp. GR2. Ins.	150K	10	$\frac{1}{4}$	Dubilier	BTT
R40	Res. Film(Carbon) GR1. Non. Ins.	1.1M	2	$\frac{1}{4}$	Welwyn	C21
R41	Res. Film(Carbon) GR1. Non. Ins.	1.1M	2	$\frac{1}{4}$	Welwyn	C21
R42	Res. Comp. GR2. Ins.	120	10	$\frac{1}{4}$	Dubilier	BTT
R43	Voltage Dependent Res.				Mullard	E299DC/P346

CAPACITORS

Cct. Ref.	Description	Value μF	Tol. %	Rating Volts	Manufacturer & Type
C1	Cap. Met. Plas. Tub. Ins	.1	10	125	Wima Tropyfol 'M'
C4	Cap. Electrolytic	100		6	Wima Printlyt
C5	Cap. Met. Plas. Tub. Ins	.22	10	400	Wima Tropyfol 'M'
C6)	See Component List of Unit in which used.				
C7)					
C8)					
C9	Cap. Met. Plas. Tub. Ins.	.047	10	400	Wima Tropyfol 'M'
C10	Cap. Electrolytic	100		6	Wima Printlyt
C11	Cap. Polystyrene	10pF	±1pF	500	Suflex H.S.
C12	Cap. Electrolytic	2		350	Hunts MEW118T
C13	Cap. Met. Foil. Tub. Ins.	.1	10	400	Wima Tropyfol 'M'
C14	Cap. Electrolytic	100		6	Wima Printlyt
C15	Cap. Electrolytic	2		350	Hunts MEW118T
C16	Cap. Met. Foil. Tub. Ins.	.047	10	400	Wima Tropyfol 'M'
C17	Cap. Met. Pap. Tub. Ins.	.01	10	630	Wima Tropyfol 'F'
C18	Cap. Met. Foil. Tub. Ins.	1000pF	20	400	Wima Tropyfol 'F'
C19	Cap. Electrolytic	100		6	Wima Printlyt
C20	Cap. Met. Tub. Ins.	0.1	10	400	Wima Tropyfol 'M'

VALVES

Cct. Ref.	Description	Manufacturer & Type
V1	Valve	Mullard/Brimar ECF82 or 6U8
V2	Valve	Mullard/Brimar ECF82 or 6U8
V3	Valve	Mullard/Brimar PCF82 or 9U8

SEMICONDUCTORS

Cct. Ref.	Description	Manufacturer & Type
VT1	Transistor	Texas Instruments 2S701 Jermyn Ind. Type TO.5
MR1	Silicon Zener Diode	International Rectifiers MEZ18T10
MR2	Diode	A.E.I. MS1H
MR3	Diode	A.E.I. MS1H
MR4	Silicon Zener Diode	International Rectifiers MEZ22T10

COMPONENTS LISTS

PRINTED CIRCUIT BOARD OOP503

RESISTORS

Cct. Ref.	Description	Value Ohms	Tol. %	Rating Watts	Manufacturer & Type	
R4	Res. Comp. GR2. Ins.	2.7M	10	$\frac{1}{4}$	Dubilier	BTT
R5	Res. Comp. GR2. Ins.	470K	10	$\frac{1}{4}$	Dubilier	BTT
R6	Res. Comp. GR2. Ins.	10M	10	$\frac{1}{4}$	Dubilier	BTT

CAPACITORS

Cct. Ref.	Description	Value μ F	Tol. %	Rating Volts	Manufacturer & Type	
C2	Cap. Met. Tub. Ins.	.047	20	125	Wima Tropyfol	'M'
C3	Cap. Met. Tub. Ins.	0.1	10	125	Wima Tropyfol	'M'

SEMICONDUCTORS

Cct. Ref.	Description	Manufacturer & Type	
MR5	Diode	Mullard	OA 202
MR6	Diode	Mullard	OA 202

MISCELLANEOUS

Cct. Ref.	Description	Rating	Manufacturer & Type	
RL1	Relay Sync. Chopper plus Chopper Top Cap.	100c/s 6.3V	A.E.I.	CK4

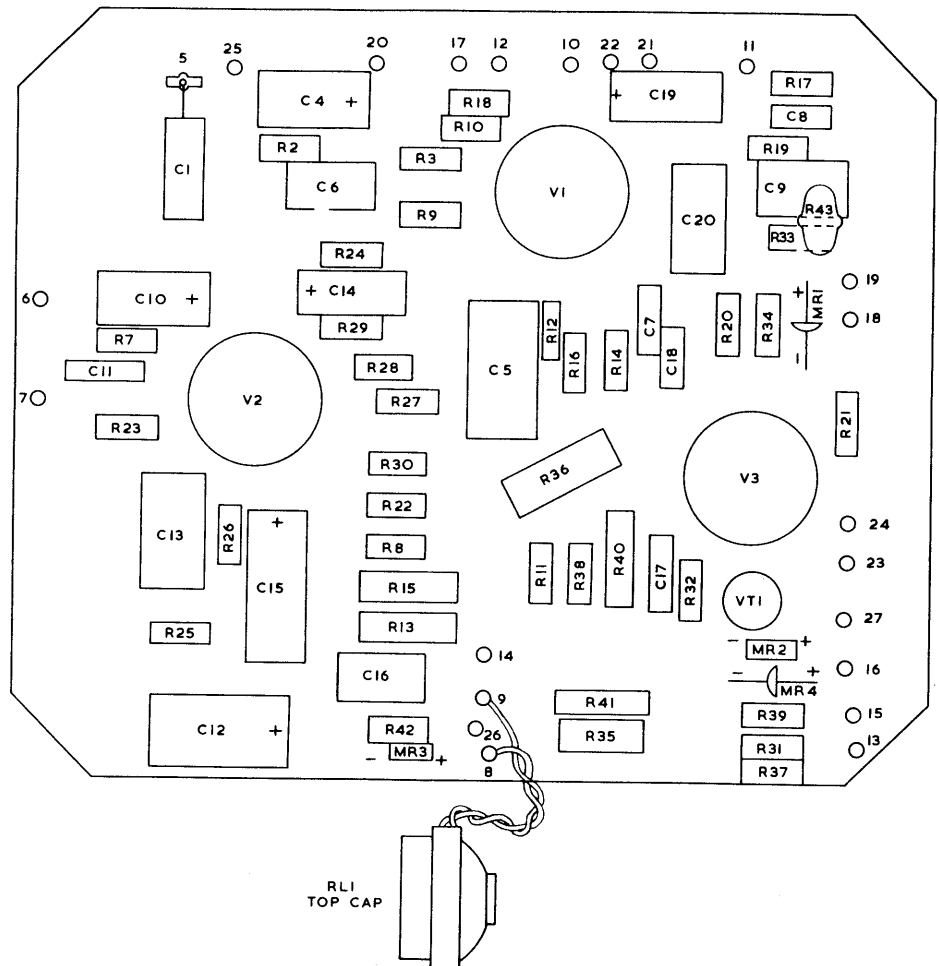
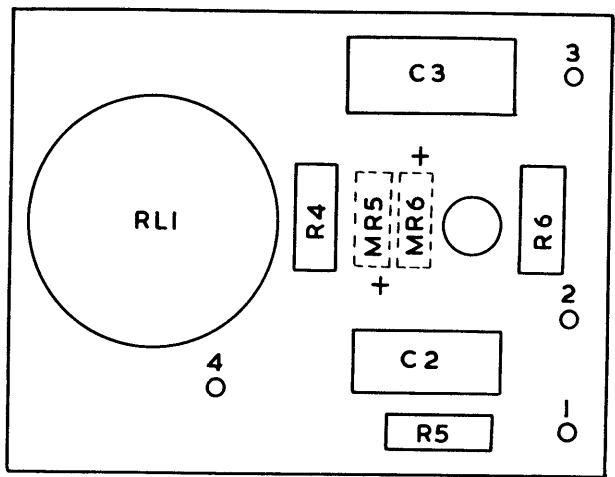

Fig. 1 - Component Location : Printed Circuit Board OOP501



NOTE :-
DIODES MR5, MR6 MOUNTED ON COPPER SIDE
OF BOARD.

APPENDIX B

Technical Manual : AS1403 Power Supply Unit

Appendix B

AS1403 POWER SUPPLY

The AS1403 Power Supply comprises an AS1104.2 Power Supply and a mains supply switching and distribution circuit. SA and SB are, respectively, the HEATER ON and HT ON switches. Sockets SKTA, SKTB, SKTC and SKTD route mains power to pins P and R, plugs PLA on a maximum of four Tutors. Socket SKTE links with plug PL1 on the AS1104.2 Power Supply.

LIST OF COMPONENTS

Cct. Ref.	Description	Solartron Part No.	Manufacturer and Type	
SA	Switch Toggle DP C/O, 6A	3760 00080	Painton	501085
SB	Switch Toggle DP C/O, 6A	3760 00080	Painton	501085
SKTA	Socket 3 Way	3515 03040	Bulgin	SA 2026
SKTB	Socket 3 Way	3515 03040	Bulgin	SA 2026
SKTC	Socket 3 Way	3515 03040	Bulgin	SA 2026
SKTD	Socket 3 Way	3515 03040	Bulgin	SA 2026
SKTE	Socket 6 Way	3514 06010	Plessey	CZ49017
AS1104.2	Power Supply (See Appendix B)			

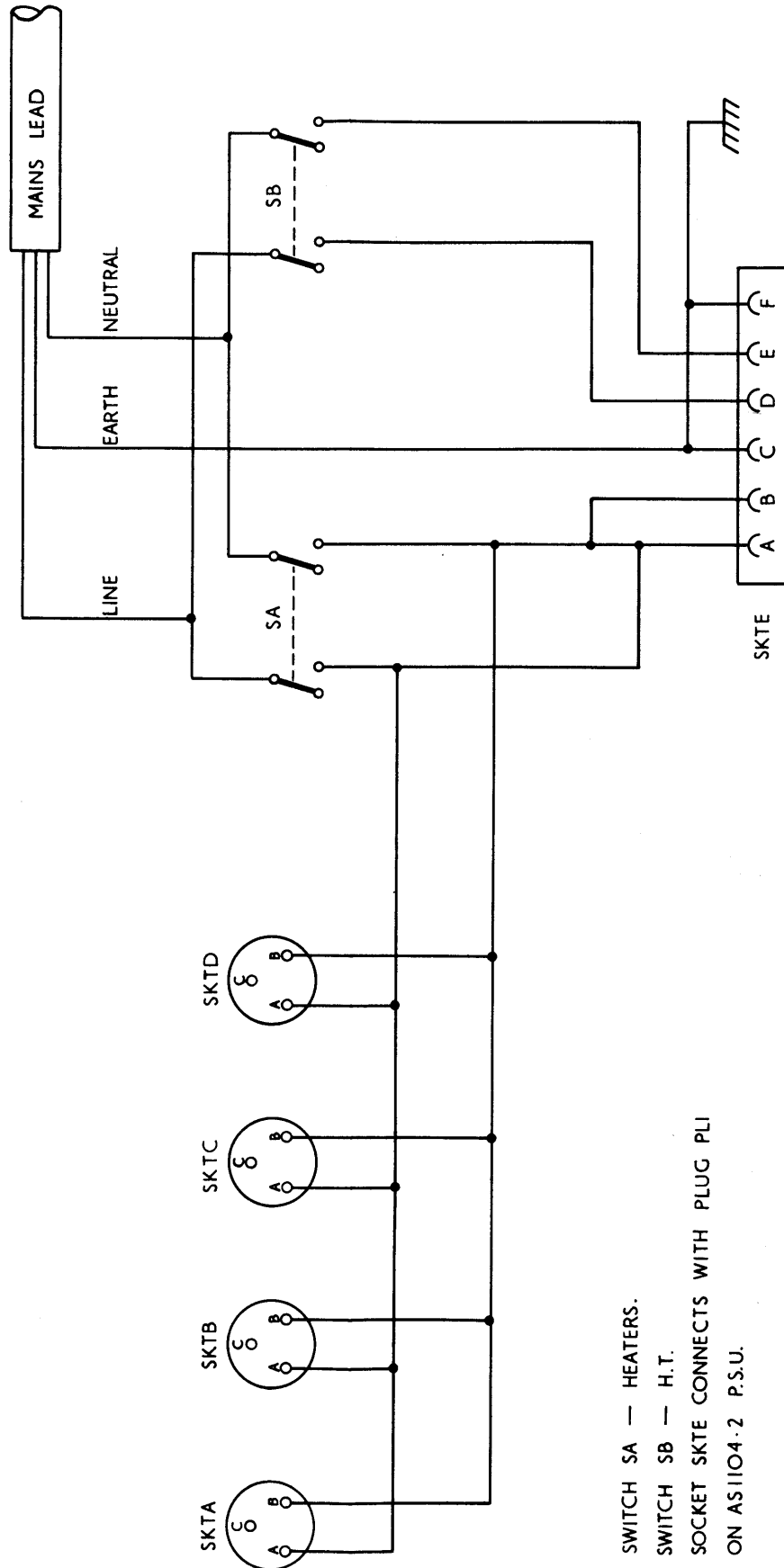

CIRCUIT DIAGRAM : AS1403 POWER SUPPLY UNIT